

Decentralized Federated Learning

CZ4079 Final Year Project: #SCSE21-0200

Student: Agarwal Hitesh

Supervisor: Prof. Dusit (Tao) Niyato

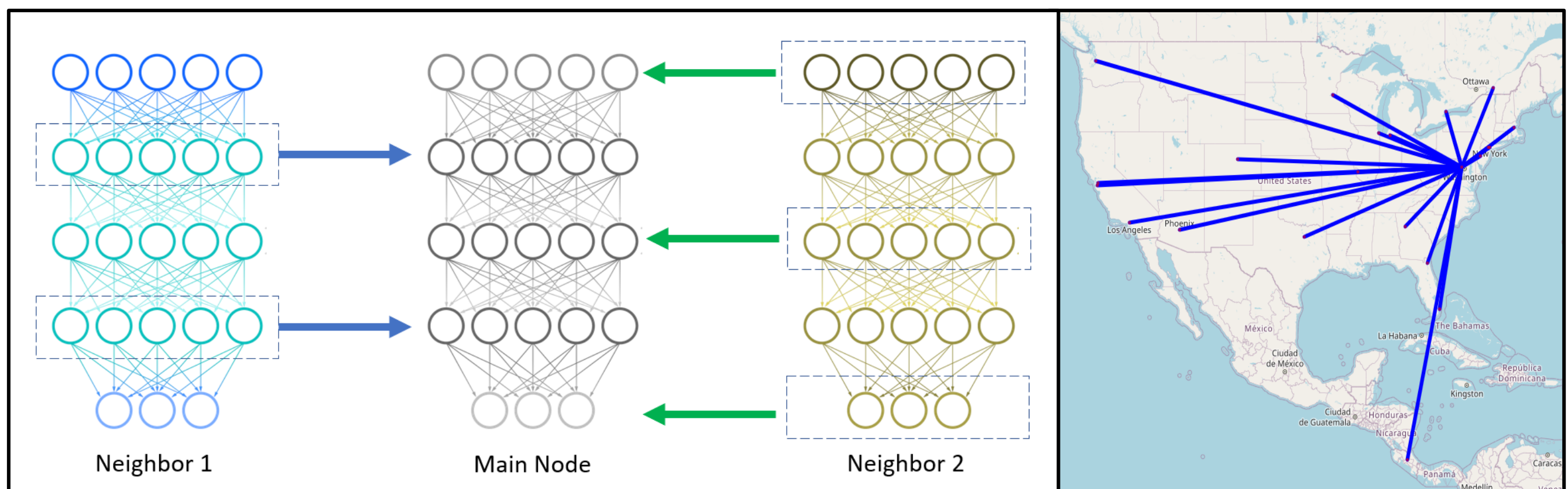

Project Objectives:

Conventional implementations of federated learning require a centralized entity to conduct and coordinate the training process with a star communication architecture. However, this technique is prone to a single point of failure, e.g., when the central node is malicious. In this study, we explore decentralized federated learning frameworks where clients communicate with each other following a peer-to-peer mechanism rather than server-client. We study how various factors like communication topology, number of local steps and model partitioning affects the throughput and convergence in decentralized federated learning under cross-silo settings. Additionally, we also include network link latencies in our performance metrics for a fair comparison against real-world scenarios.

